

## P/N: T197922

### Copyright

© 2020, FLIR Systems, Inc.

All rights reserved worldwide. Names and marks appearing herein are either registered trademarks or trademarks of FLIR Systems and/or its subsidiaries. All other trademarks, trade names or company names referenced herein are used for identification only and are the property of their respective owners.

### Document identity

Publ. No.: T197922  
 Commit: 42932  
 Language: en-US  
 Modified: 2017-05-30  
 Formatted: 2020-06-17

### Website

<http://www.flir.com>

### Customer support

<http://support.flir.com>

### Disclaimer

Specifications subject to change without further notice. Camera models and accessories subject to regional market considerations. License procedures may apply. Products described herein may be subject to US Export Regulations. Please refer to [exportquestions@flir.com](mailto:exportquestions@flir.com) with any questions.



General description	
The standard 25° lens is suitable for the majority of applications.	
Imaging and optical data	
Field of view (FOV)	25° × 19° (31° diagonally)
Minimum focus distance	250 mm (9.84 in.)
Focal length	24.6 mm (0.97 in.)
Spatial resolution (IFOV)	0.69 mrad
Lens identification	Automatic
F-number	1.0
Number of lenses	3 (3 asph)
MTF @ 70% of FOV	Normal requirements (52%)
Distortion	3%
Physical data	
Weight	0.160 kg (0.353 lb.)
Size (L × D)	41 × 67 mm (1.61 × 2.64 in.)
Front lens diameter	32 mm (1.26 in.)
Shipping information	
Packaging, type	Cardboard box
List of contents	<ul style="list-style-type: none"> <li>• Lens</li> <li>• Lens case</li> <li>• Front lens cap</li> <li>• Rear lens cap</li> </ul>
Packaging, weight	0.380 kg (0.84 lb.)
Packaging, size	174 × 133 × 133 mm (6.9 × 5.2 × 5.2 in.)
EAN-13	7332558004432
UPC-12	845188004439
Country of origin	Sweden

### Compatible with the following products:

- 55001-0101; FLIR A615 15°
- 55001-0102; FLIR A615 25°
- 55001-0103; FLIR A615 45°
- 55001-0104; FLIR A615 7°
- 55001-0105; FLIR A615 80°



## IR lens, f=24.6 mm (25°) with case

---

**P/N: T197922**

© 2020, FLIR Systems, Inc.

#T197922; r. 42932; en-US

- 55001-0301; FLIR A655sc 15°
- 55001-0302; FLIR A655sc 25°
- 55001-0303; FLIR A655sc 45°
- 55001-0304; FLIR A655sc 7°
- 55001-0305; FLIR A655sc 80°

# Camera with Lens IR f=24,6 mm (25°)

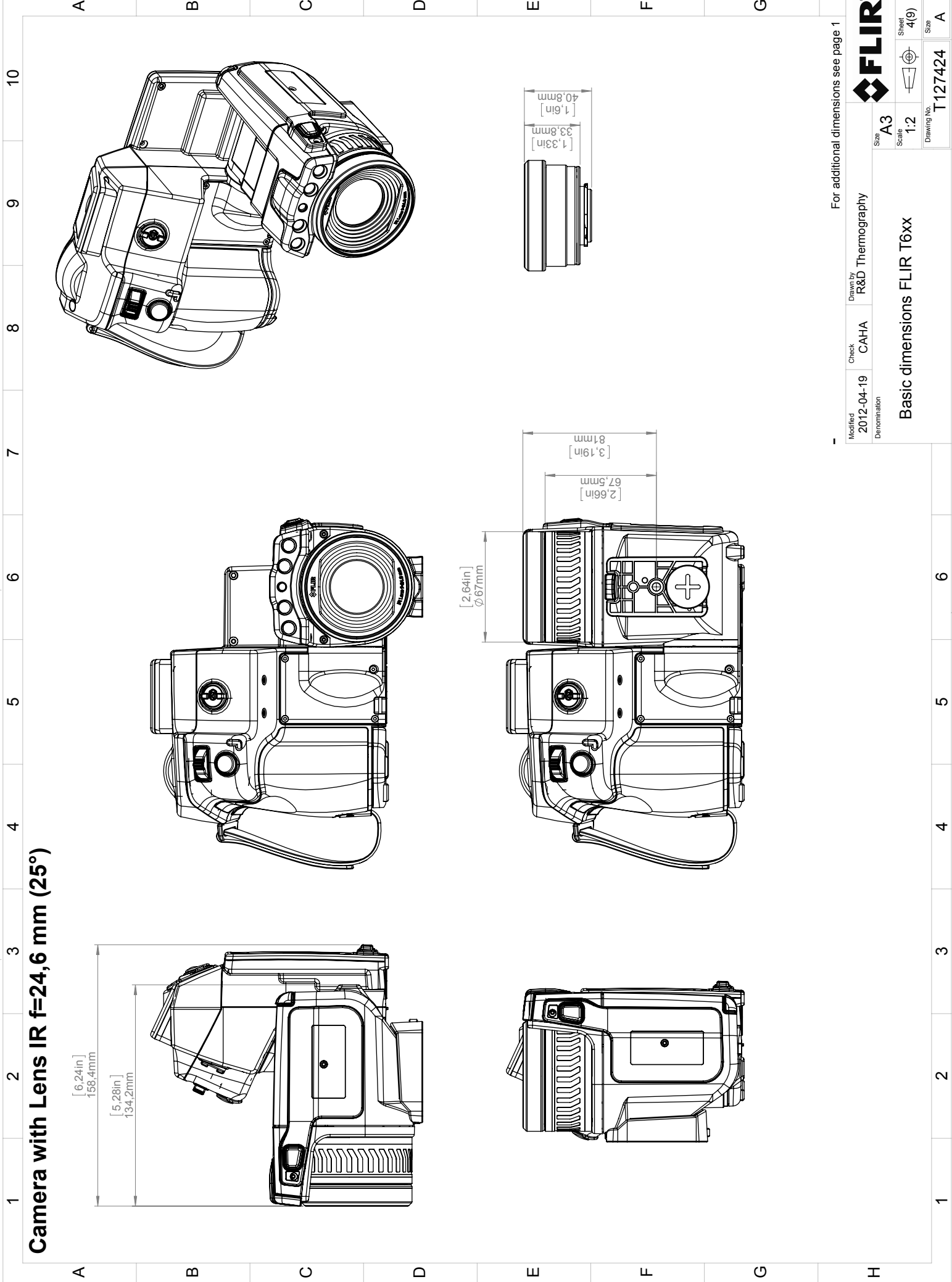
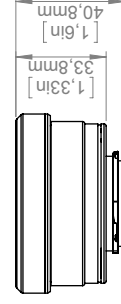
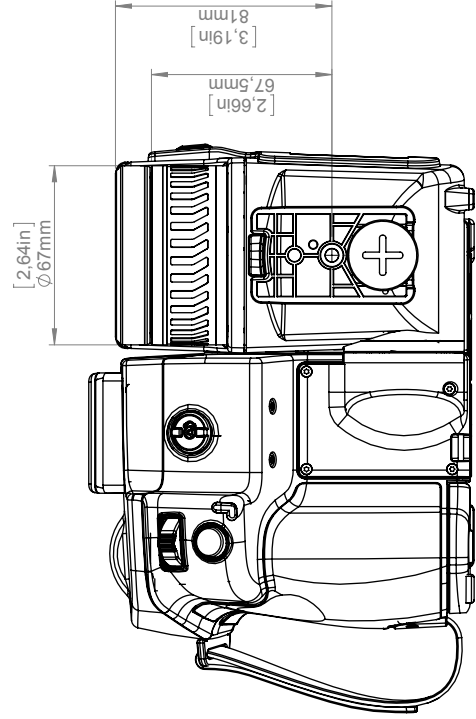
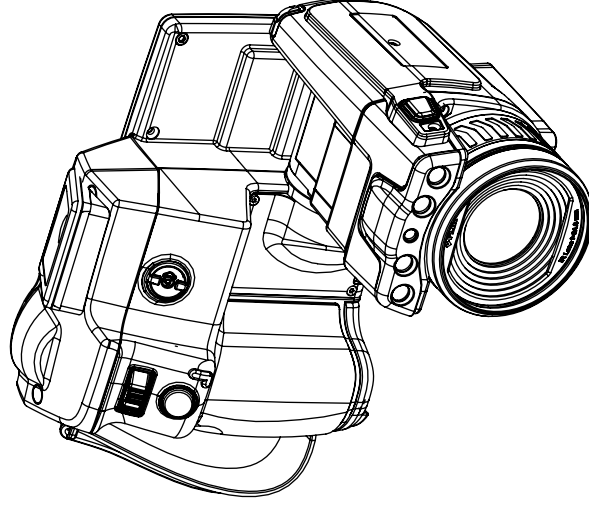
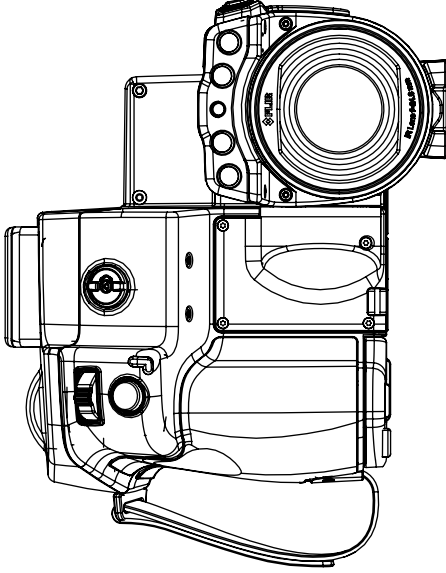
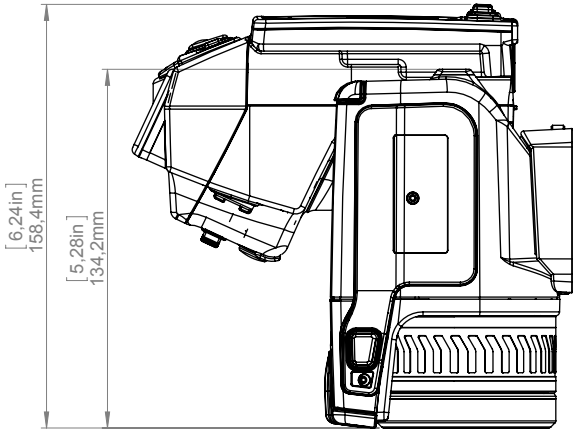

© 2012, FLIR Systems, Inc. All rights reserved worldwide. No part of this drawing may be reproduced, stored in a retrieval system, or transmitted in any form, or by any means, electronic, mechanical, photocopying, recording, or otherwise, without written permission from FLIR Systems, Inc. Specifications subject to change without further notice. Dimensional data is based on nominal values. Products may be subject to regional market considerations. License procedures may apply. Product may be subject to US Export Regulations. Please refer to exportquestions@flir.com with any questions. Diversion contrary to US law is prohibited.

For additional dimensions see page 1

Modified 2012-04-19	Check CAHA	Drawn by R&D Thermography	FLIR®
Denomination Basic dimensions FLIR T6xx			Size A3
			Sheet 4(9)
			Drawing No. T127424
			Size A

# Camera with Lens IR f=24,6 mm (25°)

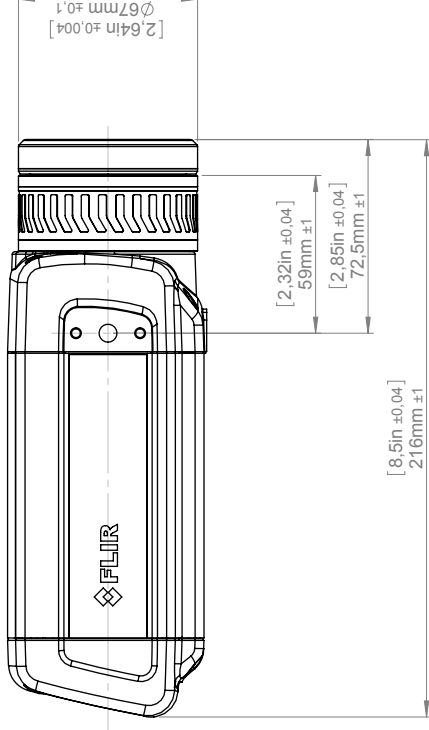
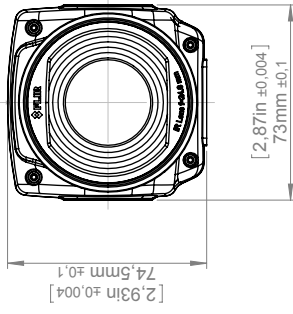
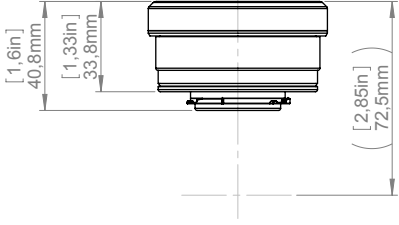
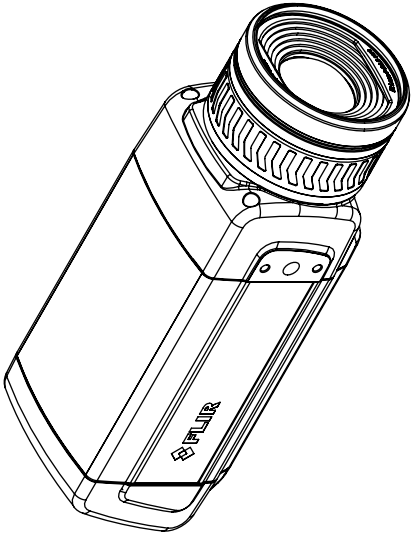

For additional dimensions see page 1

Modified 2012-04-18	Check CAHA	Drawn by R&D Thermography	FLIR®
Denomination		Size A3	Sheet 4(9)
Basic dimensions FLIR A/SC 6xx		Scale 1:2	Drawing No. T126925
			Size A

© 2012, FLIR Systems, Inc. All rights reserved worldwide. No part of this drawing may be reproduced, stored in a retrieval system, or transmitted in any form, or by any means, electronic, mechanical, photocopying, recording, or otherwise, without written permission from FLIR Systems, Inc. Specifications subject to change without further notice. Dimensional data is based on nominal values. Products may be subject to regional market considerations. License procedures may apply. Product may be subject to US Export Regulations. Please refer to exportquestions@flir.com with any questions. Diversion contrary to US law is prohibited.